

NOTES:

1. JOINTS SHALL BE KEY TYPE OR TONGUE AND GROOVE AND SHALL CONFORM WITH A.S.T.M. C-478, SECTION 14.
2. FOR 24 INCH PIPE AND LARGER, THE TOP HALF OF THE PIPE SHALL BE REMOVED TO THE CONTOUR OF THE INSIDE OF THE MAINTENANCE HOLE AND THE BROKEN EDGES PLASTERED SMOOTH WITH CEMENT MORTAR.
3. FOR PRECAST MAINTENANCE HOLE CONSTRUCTION SEE WDS 502.
4. CORE DRILL MAINTENANCE HOLE AT 2" GREATER THAN THE O.D. OF INLET PIPE. FILL ANNULAR SPACE WITH DRY PACK NONSHRINK GROUT.
5. SUBGRADE SHALL BE OVEREXCAVATED 2 FEET BELOW BOTTOM OF MAINTENANCE HOLE BASE AND REPLACED WITH CRUSHED ROCK. MAINTENANCE HOLE BASE ON UNDISTURBED SOIL IF APPROVED BY LBWD.
6. PLASTIC JOINT: PREFORMED COLD APPLIED READY TO USE PLASTIC JOINT SEALING COMPOUND SHALL BE CON-SEAL SEALANT, OR APPROVED EQUAL.

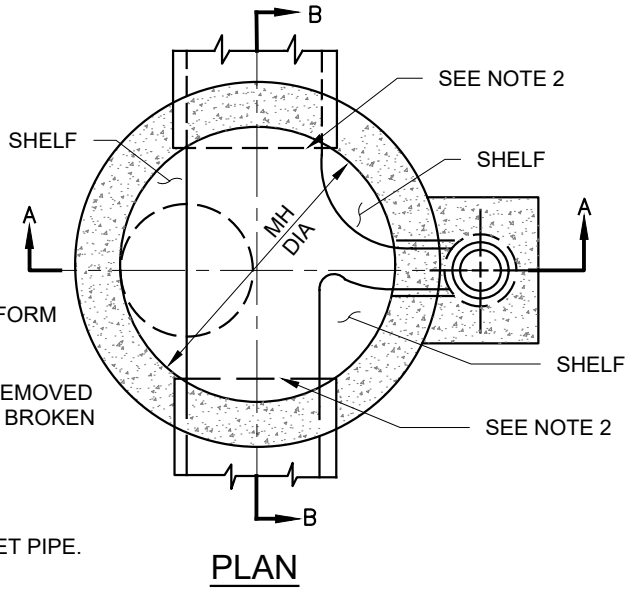

DROP MAINTENANCE HOLE

WDS - 503



RECOMMENDED <i>Robert Johnson</i> DIRECTOR OF ENGINEERING	APPROVED <i>Shirley Paul</i> DEPUTY GENERAL MANAGER / CHIEF ENGINEER
DATE: 02-2020	SCALE: N.T.S.
SHEET 1 OF 1	