

**CUT-IN WYE ON EXISTING  
SEWER PIPE**

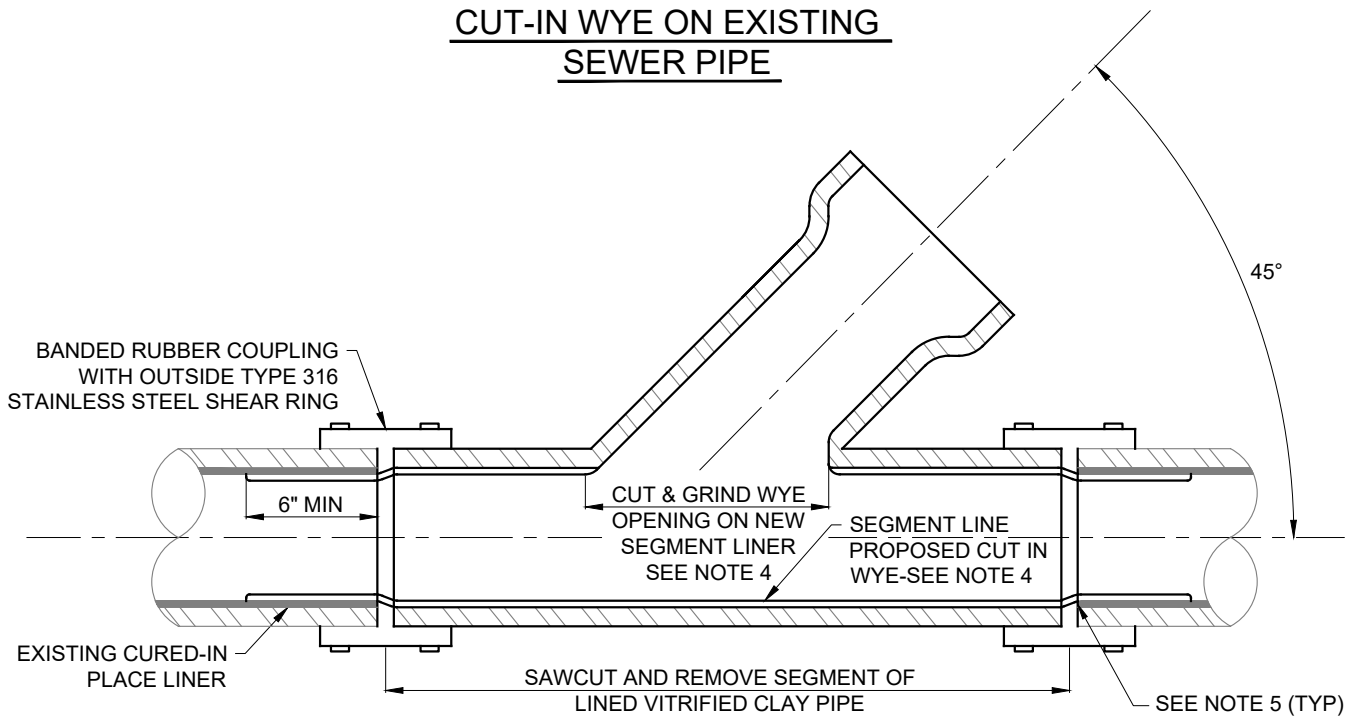

**CUT-IN WYE ON EXISTING  
LINED SEWER PIPE**

**NOTES:**

1. WHEN 12" MIN. SPACE BETWEEN EDGE OF COUPLING AND BELL CANNOT BE PROVIDED, CUT OUT NEAREST BELL JOINT AND INSERT PLAIN END PIPE.
2. ALL DEBRIS SHALL BE KEPT OUT OF THE SEWER. THE PIPE REACH CUT INTO SHALL BE CLEANED AND BALLED, IF NECESSARY, AS DIRECTED BY LBWD.
3. DAMAGED PIPE SHALL BE REPLACED AS DIRECTED BY LBWD.
4. INSTALL SEGMENT LINER ACROSS THE CUT IN WYE AS REQUIRED BY LBWD. CUT AND GRIND OPENING FOR NEW SERVICE.
5. FILL ANNULAR SPACE BETWEEN PIPE AND LINER WITH SIKADUR 31 OR APPROVED EQUAL.

**CUT-IN WYE ON EXISTING SEWER**

**WDS - 513**



**Long Beach Water**  
Exceptional Water • Exceptional Service

RECOMMENDED

*Robert Johnson*

DIRECTOR OF ENGINEERING

APPROVED

*Shirley Paul*

DEPUTY GENERAL MANAGER / CHIEF ENGINEER

DATE: 02-2020

SCALE: N.T.S.

SHEET 1 OF 1